

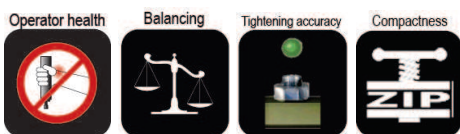

Suspended arms

Slider



SLIDER Series : Erase your torque reaction until 300 Nm.

- IMPROVE YOUR COMFORT AND PRODUCTIVITY

Easy to install and smart-sized the SLIDER arms improve the comfort of the operator and the productivity clearing the work area.

- IMPROVE YOUR ERGONOMY

Mounted with horizontal stroke the SLIDER becomes the ideal ergonomical solution on conveyor line.

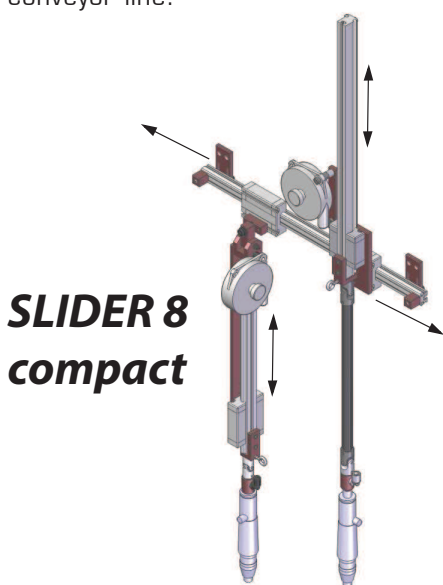

**SLIDER 8
compact**

SLIDER 8/20

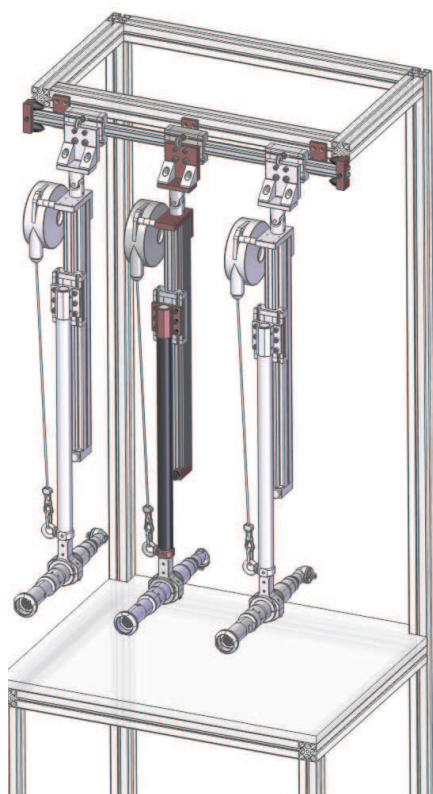

SLIDER 50/150 COMPACT
Tightening vertical/horizontal

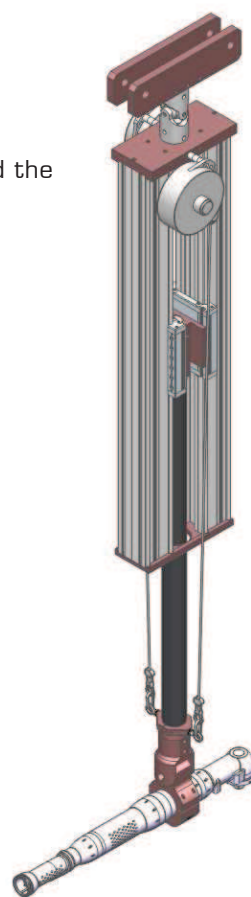

**SLIDER 300
COMPACT**

Model	Max torque (Nm)	Clamping Ø (mm)	Vertical stroke (mm)	Working radius (mm)	Load (kg)	Code
SLIDER 08	8	1/4" G	450	100	1,2	4-1200077
SLIDER 08 COMPACT	8	1/4" G	250	150	1,2	4-1200179
SLIDER 20	20	1/4" G	450	100	2,2	4-1200457
SLIDER 50 COMPACT 450	50	32 - 52	450		3	4-1283110
SLIDER 50 COMPACT 650	50	32 - 52	650		3	4-1283111
SLIDER 50 COMPACT 850	50	32 - 52	850		3	4-1283112
SLIDER 150 COMPACT 600	150	Max 63	600		5	4-1283113
SLIDER 150 COMPACT 800	150	Max 63	800		5	4-1283114
SLIDER 150 COMPACT 1000	150	Max 63	1000		5	4-1283115
SLIDER 300 COMPACT	300	On request	On request	On request	On request	On request

Suspended arms

Options SLIDER

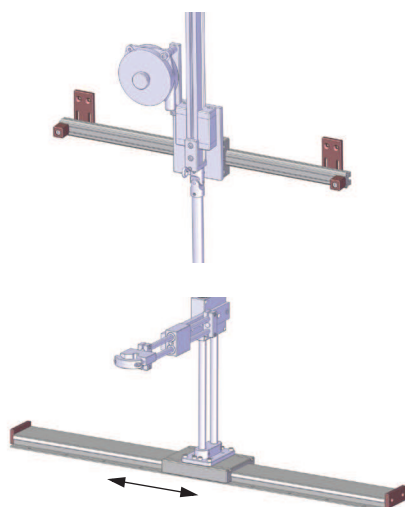

Rails / SLIDER 8/20/50

Length (mm)	Stroke (mm)	Number of flanges	Code
600	450	2	4-1200132
800	650	2	4-1200160
1000	850	2	4-1200161
1200	1050	3	4-1200162
1500	1350	3	4-1200163
2000	1850	4	4-1200164

Rails / SLIDER 150

Model	Length (mm)	Stroke (mm)	Code
Guiding rail	600	420	4-1200294
Guiding rail	1000	820	4-1200295
Guiding rail	1500	1320	4-1200296
Guiding rail	2000	1820	4-1200297



Clamp option

Clamp Ø28-52 mm for angle nutrunner for SLIDER 20 **Code : 4-1200392.**



Clamp for straight electric screwdriver

For	Clamping	Tool Ø (mm)	Code
SLIDER 8	On the top of the screwdriver	28 - 52	4-1200133
SLIDER 20	On the top of the screwdriver	28 - 52	4-1200148

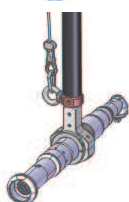

Rotative clamp

For	Clamping Ø (mm)	Code
SLIDER 50 COMPACT	35 - 52	4-1283116
SLIDER 150 COMPACT	Max 63	4-1283117

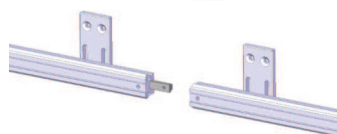

Rail link

To link two rails together. **Code 4-1200307**

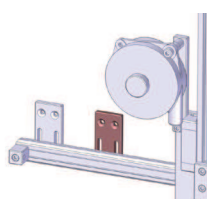

Additional flange

To reinforce the rail installation for high torque applications.

Code 4-1200873

Rail interface

For	Code
Rail interface for SLIDER50	4-1200708
Rail interface for SLIDER150	4-1200009



Suspended arms

SLIDER 8/8 COMPACT/20 Dimensions

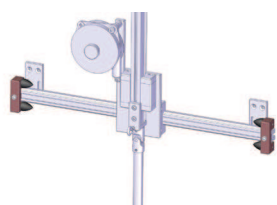

Absorbing stop

Recommended in case of repeatable side shocks.

Code 4-1201121 Set of 2

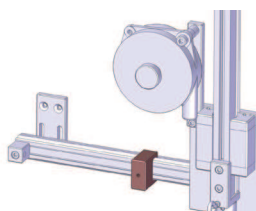

Adjustable stop

To limit the slide of the arm on the rail.

Code 4-1200167

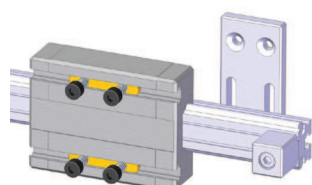

Single trolley

To mount additional tools on the same rail.

- Single trolley Code 4-1200165

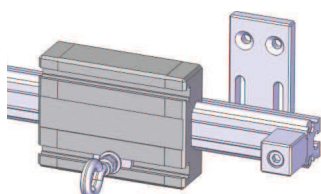

- Trolley for additional balancer Code 4-1200166

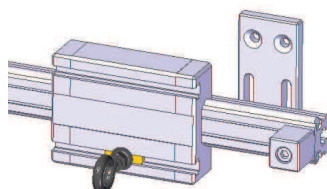

Additional safety tool hook

To secure balancer. Code 4-1200309

Suspended arms

SLIDER 8/20 Dimensions

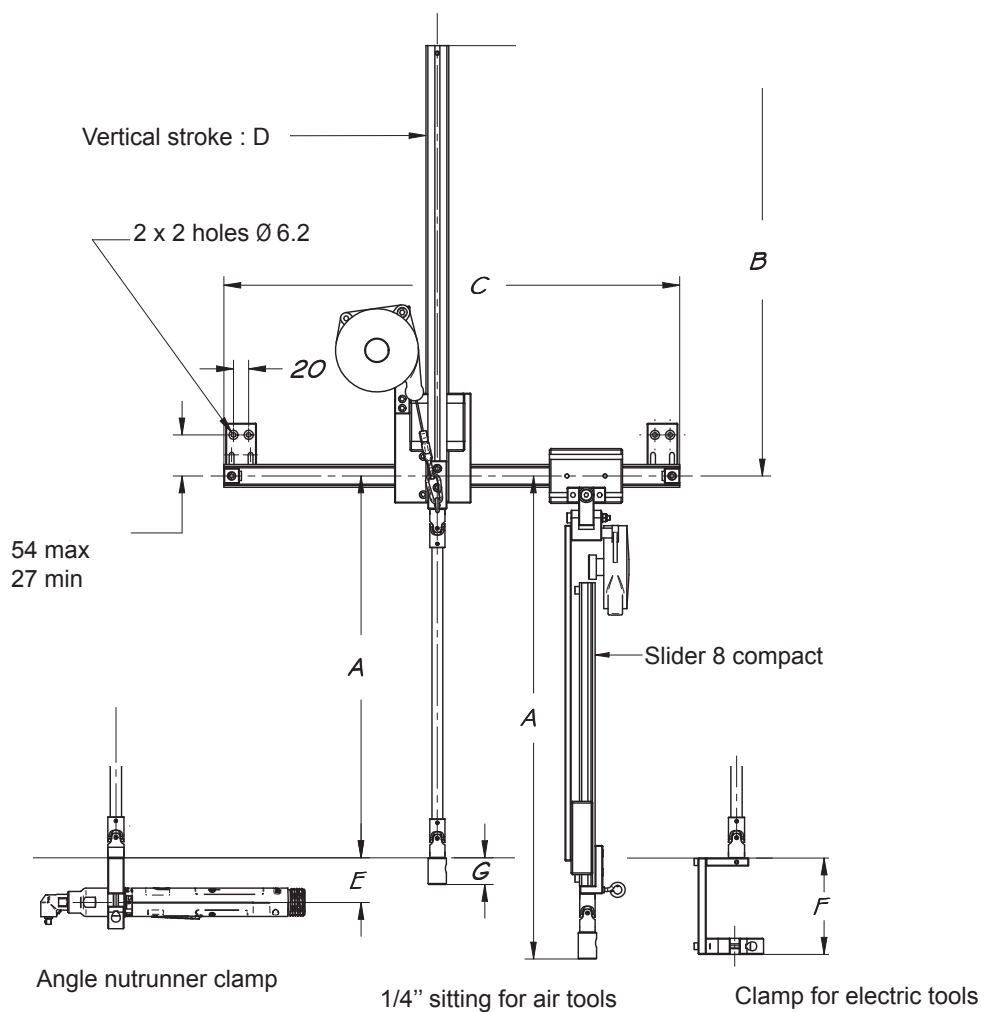

Dimensions

Model	A	B	Vertical stroke D	E	F	G
SLIDER 8	500	565	450	/	120	35
SLIDER 8 COMPACT	550 to 600	/	270	/	120	35
SLIDER 20	500	599	450	56	120	35

Rails

Stroke	Length : C
450	600
650	800
850	1000
1050	1200
1350	1500
1850	2000



Suspended arms

SLIDER BA / SLIDER BA...R Series

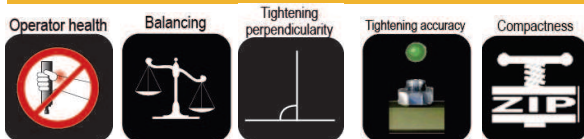

Mounted on the top, the working area remains free. The SLIDER Series can be installed on rail. Then a pneumatic locker is necessary to counter react.

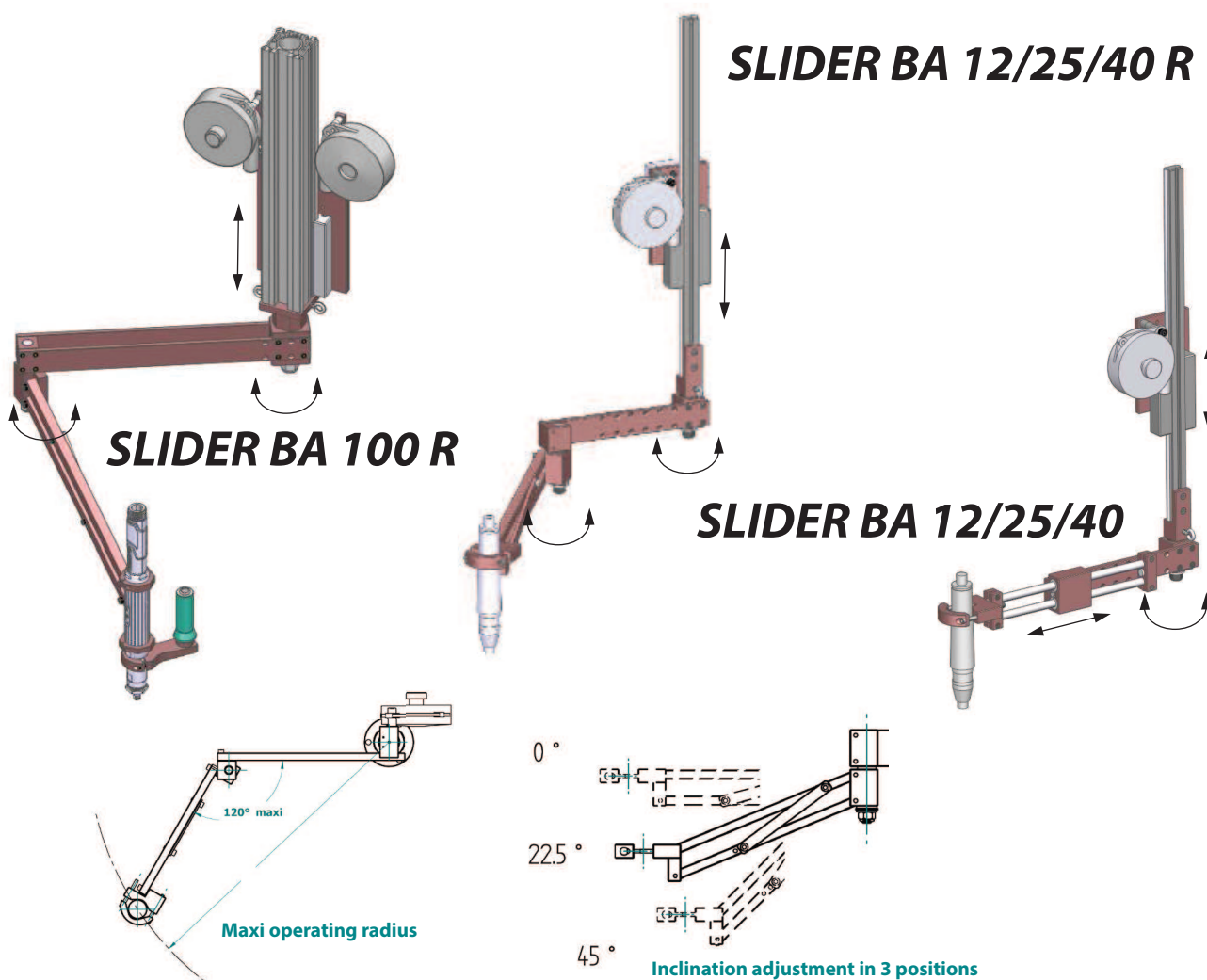

Model	Max torque (Nm)	Tool Ø (mm)	Vertical stroke (mm)	Stroke (mm)	Operating range (mm)	Load (kg)	Code
SLIDER BA 12	12	25/50	420	225		1,2	4-1201007
SLIDER BA 25	25	28/52	420	250		2,2	4-1200726
SLIDER BA 40	40	28/52	420	295		3	4-1201119
SLIDER BA 100	100	28/52	420	330		5	4-1201120
SLIDER BA 12 R	12	25/50	420		450	1,2	4-1201008
SLIDER BA 25 R	25	28/52	420		460	2,2	4-1200872
SLIDER BA 25 R/600	25	28/52	420		600	2,2	4-1201114
SLIDER BA 40 R	40	28/52	420		650	3	4-1201115
SLIDER BA 40 R/800	40	28/52	420		800	3	4-1201116
SLIDER BA 100 R	100	28/52	420		730	5	4-1201117
SLIDER BA 100 R/900	100	28/52	420		900	5	4-1201118

Suspended arms

SLIDER BA / BA...R Dimensions

SLIDER BA...R

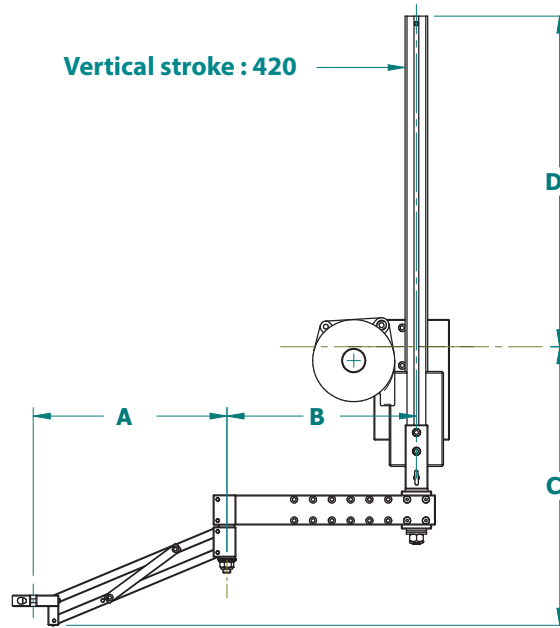

22.5°

Model	A	B mini	B maxi	Operating range at 120°	C	D
SLIDER BA 12 R	261	102	252	474	370	440
SLIDER BA 25 R	278	95	245	485	394	425
SLIDER BA 25 R/600	336	305	330	607	417	425
SLIDER BA 40 R	387,5	150	350	667	482	419
SLIDER BA 40 R/800	470	415	415	800	496	419
SLIDER BA 100 R	433	205	405	730	597	358
SLIDER BA 100 R/900	528	470	520	900	634	358

SLIDER BA...

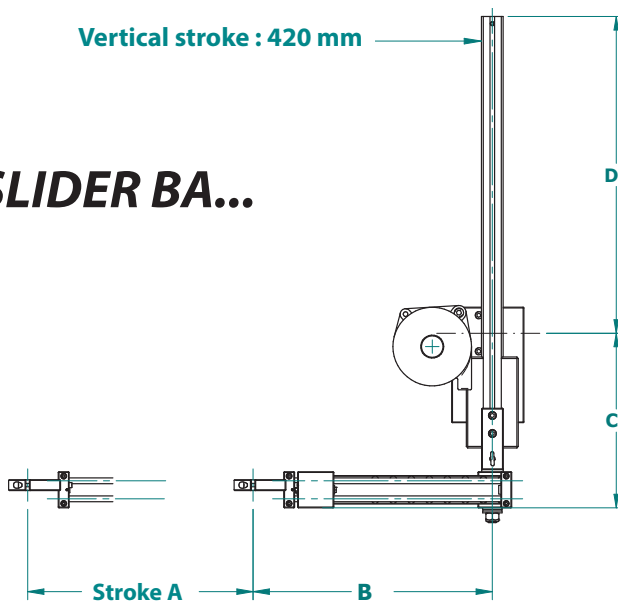

Mounting dimensions SLIDER BA... BA...R

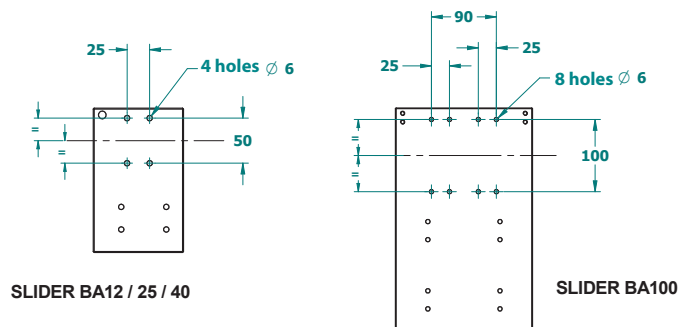

Model	Stroke A	B mini	B maxi	C	D
SLIDER BA 12	225	186	336	246	436
SLIDER BA 25	250	221	396	250	436
SLIDER BA 40	295	260	460	314	419
SLIDER BA 100	330	315	515	395	358